

COMPONENTS

1. ALUMINUM L152x102x9.5 FRAME
2. 6.35mm TREAD PLATE
3. REINFORCING - TO SUIT LOADING
4. SELF LOCKING HOLD OPEN ARM
5. SS SLAM LOCK C/W OPERATING KEY, PLUG
6. LOCK HASP / LOCK BY CUSTOMER
7. SS LIFT ASSIST MECHANISM (OPTIONAL)
8. SS $\phi 16$ PIN / 9.5mm PLATE HINGE.
9. SAFETY GRATE ALU. 38x5 (ORANGE).
10. GRATE HINGE ALU. 9.5mm PLATE

ALL HARDWARE 316 SS

MILL FINISH EXCEPT WHERE IN CONTACT WITH CONCRETE, THEN (2) COATS OF BITUMASTIC PAINT

ACCESS HATCH REINFORCED FOR A LIVE LOAD OF 4.7kPa (100 psf)

SAFETY GRATE : LIVE LOAD OF 4.7kPa (100 psf)

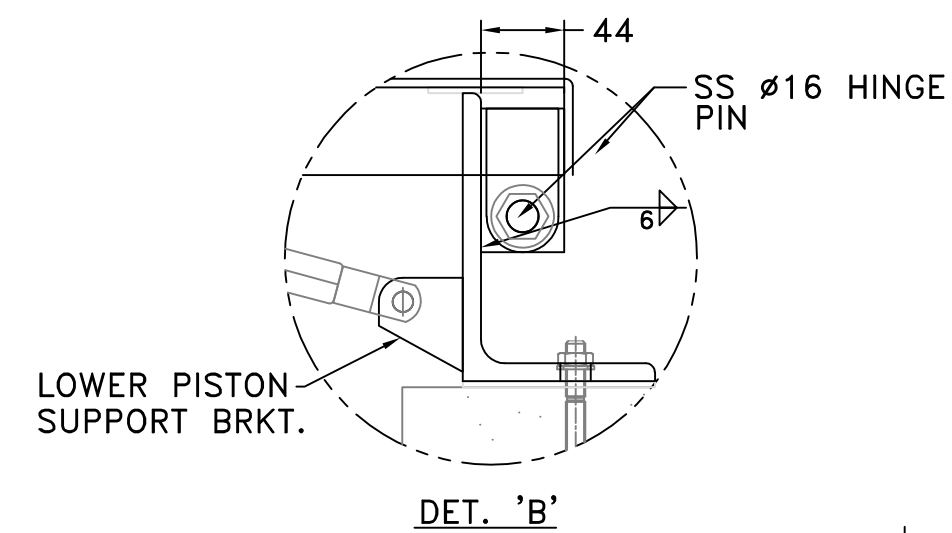
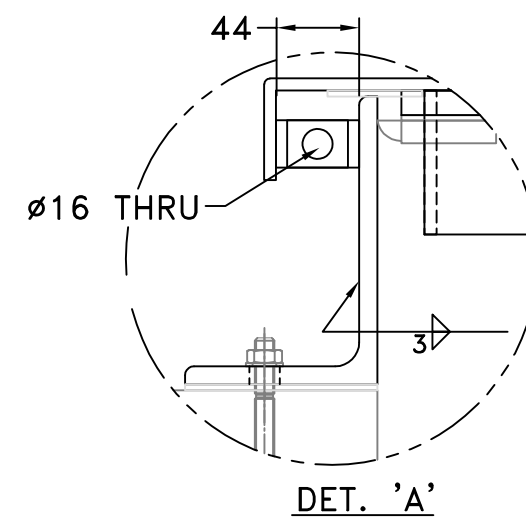
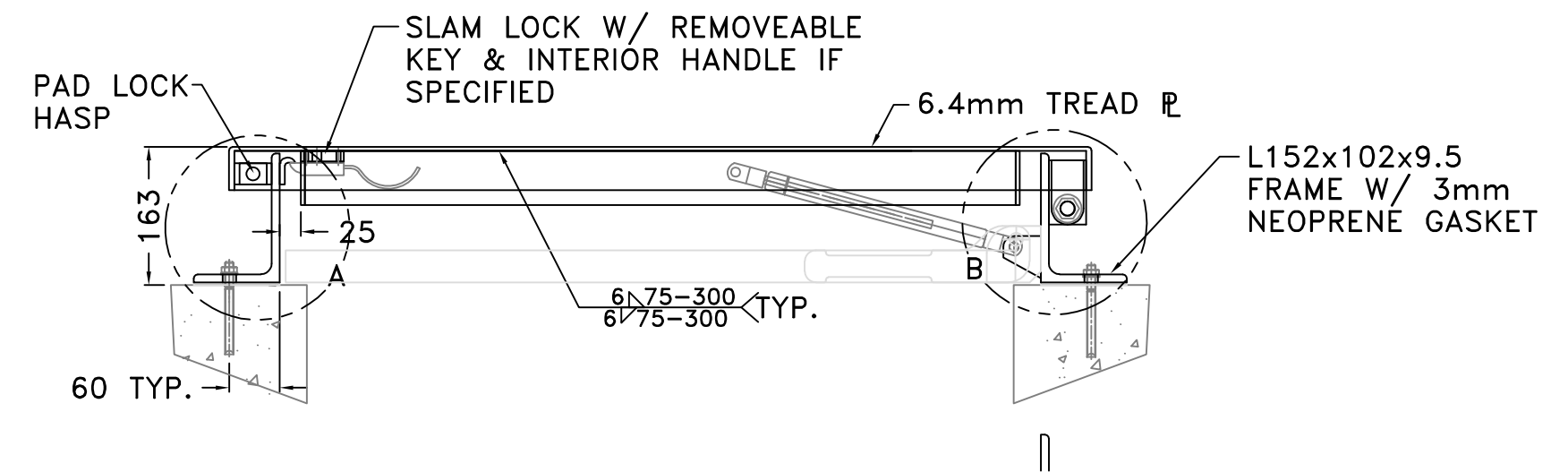
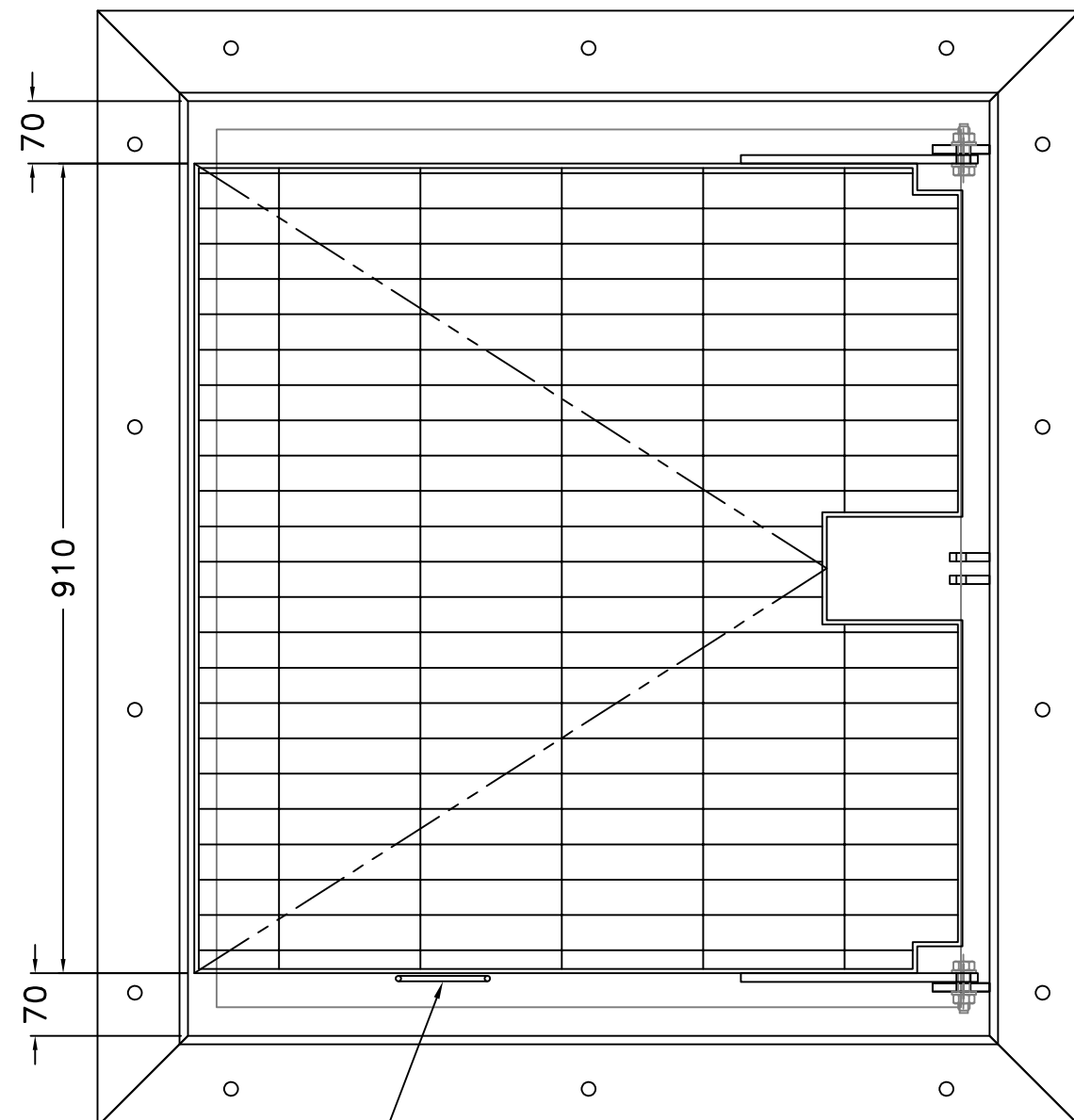
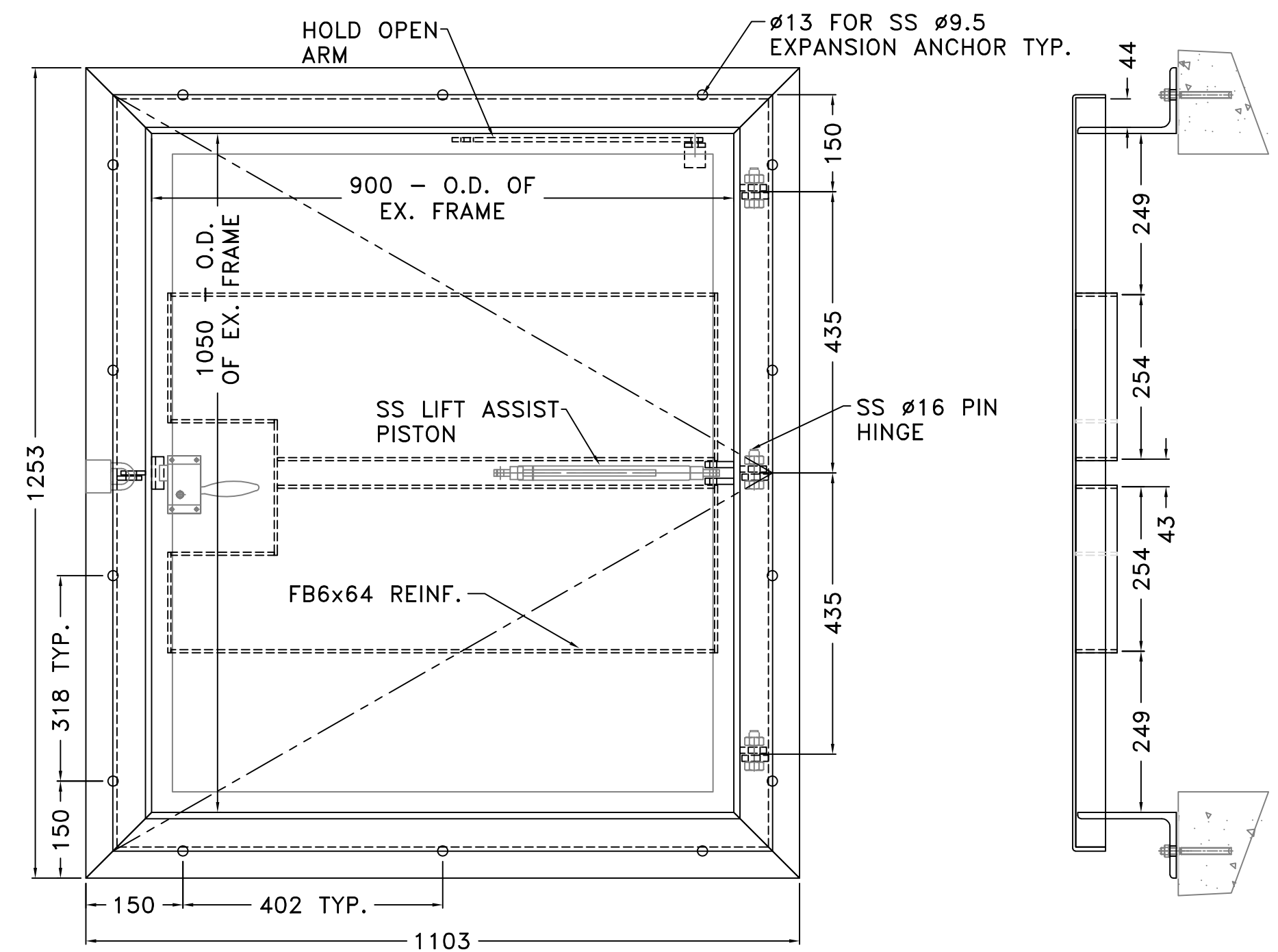

GRATING LIFT HANDLE TO LOCK INTO LID IN OPEN POSITION

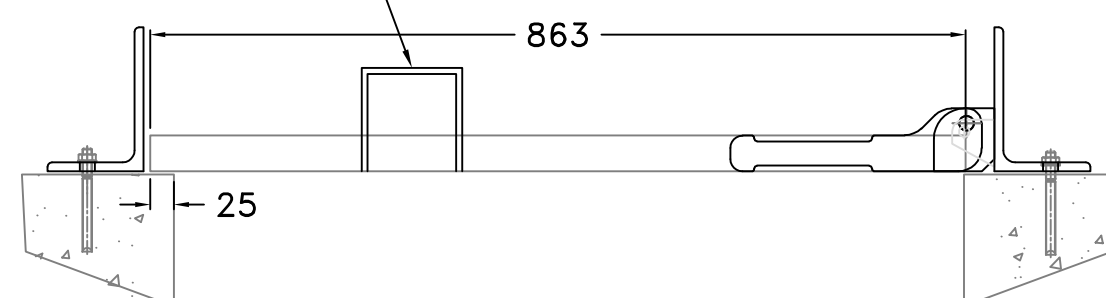

BAR IS 25MM ON ORIGINAL DRAWING

QTY:	(1) ASSY.	DIMENSIONS ARE IN MILLIMETERS U.N.O.
MATERIAL:	ALUMINUM 6061-T6 U.N.O.	
FINISH:	MILL U.N.O.	
INSTALLED BY:	X	TOLERANCE ± -

REVISIONS	
TRADE-TECH INDUSTRIES	
PROJECT No.:	1792
PROJECT TITLE:	X
CUSTOMER:	
DRAWING TITLE:	3200SL SG 1050X900
DRAWN:	LUNT
CHECKED:	
DATE:	FEB 7/19
SCALE:	NTS
SIZE:	C
DRAWING NUMBER:	1792-03
REV	0